



**ALUMINIUM CANS
& BOTTLES**

ALUMINIUM MONOBLOC CANS

DIAMETER	HEIGHT	SHOULDER		SHAPES
		FLAT	DOME	
mm	mm	FLAT	DOME	
22	55 - 80		x	
27.5	55 - 150		x	
31.5	55 - 165		x	
35	55 - 165		x	
38	90 - 165		x	x
40	90 - 165		x	x
45	90 - 180	x	x	x
50	90 - 180	x	x	x
53	90 - 180	x	x	x

Cans of various dimensions can be supplied along with the following attributes:

- Cylindrical and/or customized profile
- Externally coated in whit or colour, transparent or opaque
- Internally plain or lacquered
- Offset printing with up to 5 colours
- Clear over-varnish (glossy, matt or special effect)
- Embossed and debossed cans
- Hot stamper foiled cans

Tolerance as per IS:8449 & FEA standards.

Ø22 & 25 mm (15 mm Valve)

- COD: 20.00 mm +/- 0.1 mm
- CID: 15.00 mm +/- 0.1 mm
- CH: 2.66 mm +/- 0.1 mm

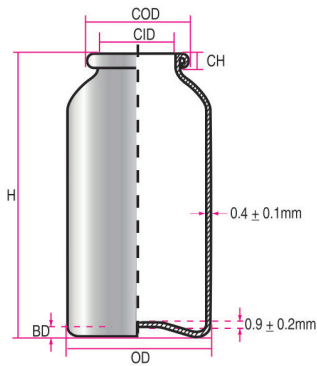

Ø30 mm & above (25.4 mm Valve)

- COD: 31.27 mm +/- 0.1 mm
- CID: 25.40 mm +/- 0.1 mm
- CH: 3.30 mm +/- 0.1 mm

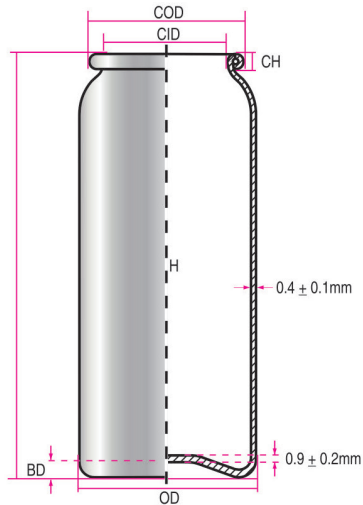

ALUMINIUM BOTTLES

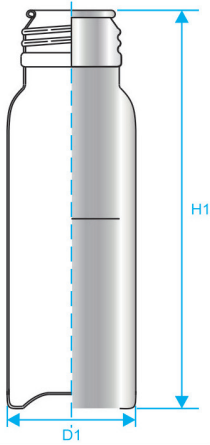

DIAMETER D1	HEIGHT H1
mm	mm
27,5	60 - 80
35	90 - 165
38	90 - 165
45	90 - 165
50	90 - 180